

**Large capacity industrial engines with high torque and a long service life**

**Hydrodynamic drive unit for fast acceleration and direction changes**

**Comfortable operator's cab featuring exemplary ergonomics**

**Isolated, cushion mounted cab**

**Catalytic converter standard on all TFG trucks**



## **DFG/TFG 316–320**

### **Diesel and gas forklifts with hydrodynamic drive units (1600, 2000 kg)**

Jungheinrich hydrodynamic diesel and gas forklift trucks have an incredible handling capacity in a variety of applications. The hydrodynamic drive performs especially well in medium to long distance operations and also ensures smooth shock-free drive from rest.

Large capacity industrial engines generate high torque even at low speeds. The benefits of this include lower fuel consumption and noise. These robust engines are

specially designed for use in forklift trucks. That ensures high reliability and a long service life even for tough applications.

All the engines feature low emissions and comply with the future EU Directives. The gas versions are fitted as standard with a catalytic converter. A closed-loop 3-way catalytic converter (TFG) and various particulate filter systems (DFG) are available as options.

The operator's cab has an ergonomic layout and is designed around the operator. This ensures safety, protects health and enables the operator to concentrate fully on his work whilst being in a relaxed & stress free environment. Overall this ensures maximum productivity for arduous shifts.

# DFG/TFG 316–320

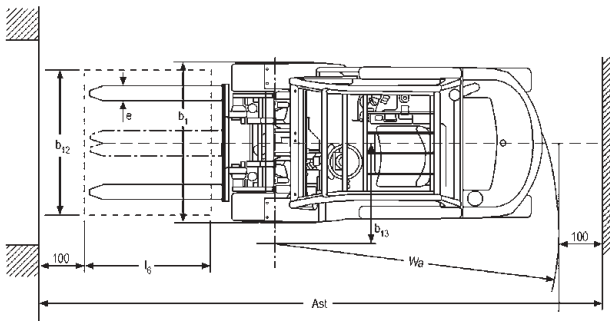
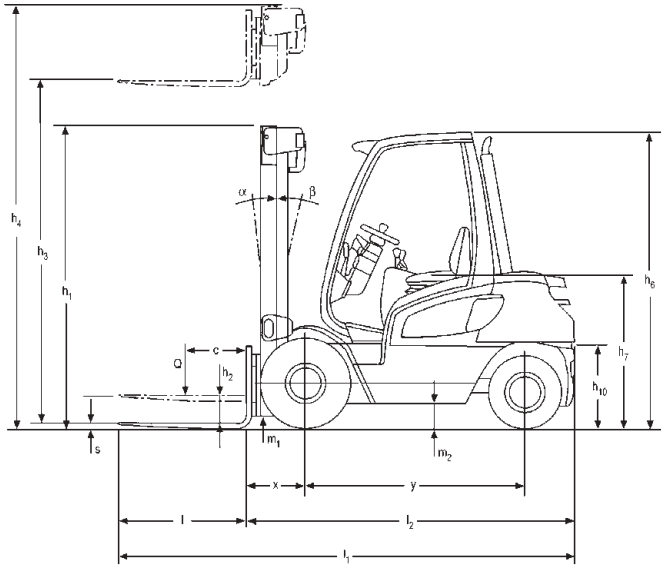

## Capacity

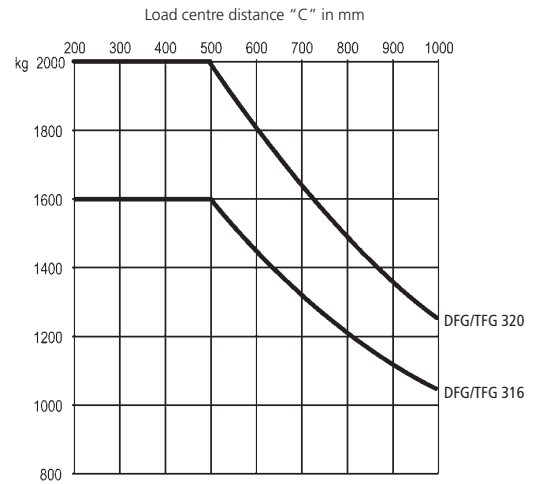

Designation	Mast table DFG/TFG 316–320					Capacity table (kg) c = 500 mm	
	Lift	Free lift	Closed mast height	Max. height	Tilt forward/backward $\alpha/\beta$ (°)	without sideshift, single solid tyres	
	$h_3$ mm	$h_2$ mm	$h_1$ mm	$h_4$ mm		DFG/TFG 316	DFG/TFG 320
Two-stage ZT	2900	150	1985	3520	7/7	1600	2000
	3100	150	2085	3720	7/7	1600	2000
	3300	150	2185	3920	7/6	1600	2000
	3600	150	2335	4220	7/6	1600	2000
	3800	150	2435	4420	7/6	1600	2000
	4000	150	2535	4620	7/6	1600	2000
	4500	150	2835	5120	7/6	1600	2000
	5000	150	3085	5620	7/6	1500	1800
Two-stage ZZ	2900	1290	1940	3550	7/7	1600	2000
	3100	1390	2040	3750	7/6	1600	2000
	3300	1490	2140	3950	7/6	1600	2000
	3600	1640	2290	4250	7/6	1600	2000
	3800	1740	2390	4450	7/6	1600	2000
	4000	1840	2490	4650	7/6	1600	2000
Three-stage DZ	4200	1290	1940	4850	7/5	1600	2000
	4350	1340	1990	5000	7/5	1600	2000
	4500	1390	2040	5150	7/5	1600	1700
	4800	1490	2140	5450	7/5	1500	1600
	5000	1565	2215	5650	7/5	1600	1600
	5500	1740	2390	6150	7/5	1350	1250
	6000	1940	2590	6650	7/5	1200	950
6500	2190	2840	7150	7/5	–	–	

# Technical Data in line with VDI 2198 as at: 09/2005

Identification	1.1	Manufacturer (abbreviation)	Jungheinrich	Jungheinrich	Jungheinrich	Jungheinrich	1.1
	1.2	Manufacturer's type designation	<b>DFG 316</b>	<b>TFG 316</b>	<b>DFG 320</b>	<b>TFG 320</b>	1.2
	1.3	Drive (electric – battery or mains, diesel, petrol, fuel gas, manual)	diesel	fuel gas	diesel	fuel gas	1.3
	1.4	Type of operation (hand, pedestrian, standing, seated, order picker)	seated	seated	seated	seated	1.4
	1.5	Load capacity/rated load Q (t)	1.6	1.6	2	2	1.5
	1.6	Load centre distance c (mm)	500	500	500	500	1.6
	1.8	Load distance, centre of drive axle to fork x (mm)	403 <sup>1)</sup>	403 <sup>1)</sup>	403 <sup>1)</sup>	403 <sup>1)</sup>	1.8
	1.9	Wheelbase y (mm)	1400	1400	1400	1400	1.9
	Weights	2.1	Service weight kg	3020	3000	3270	3250
2.2		Axle loading, laden front/rear kg	4000/620	4030/570	4600/670	4630/620	2.2
2.3		Axle loading, unladen front/rear kg	1320/1700	1270/1730	1240/2030	1190/2060	2.3
Wheels, Chassis	3.1	Tyres (solid rubber, superelastic, pneumatic, polyurethane)	SE/SE	SE/SE	SE/SE	SE/SE	3.1
	3.2	Tyre size, front	6.50-10 (14 PR)	6.50-10 (14 PR)	6.50-10 (14 PR)	6.50-10 (14 PR)	3.2
	3.3	Tyre size, rear	18x7-8 (16 PR)	18x7-8 (16 PR)	18x7-8 (16 PR)	18x7-8 (16 PR)	3.3
	3.5	Wheels, number front/rear (x = driven wheels)	2x/2	2x/2	2x/2	2x/2	3.5
	3.6	Track width, front b <sub>10</sub> (mm)	893	893	893	893	3.6
	3.7	Track width, rear b <sub>11</sub> (mm)	870	870	870	870	3.7
	Basic Dimensions	4.1	Mast/fork carriage tilt forward/backward $\alpha/\beta$ (°)	7/6	7/6	7/6	7/6
4.2		Lowered mast height h <sub>1</sub> (mm)	2185	2185	2185	2185	4.2
4.3		Free lift h <sub>2</sub> (mm)	150	150	150	150	4.3
4.4		Lift height h <sub>3</sub> (mm)	3300	3300	3300	3300	4.4
4.5		Extended mast height h <sub>4</sub> (mm)	3920	3920	3920	3920	4.5
4.7		Overhead load guard (cab) height h <sub>6</sub> (mm)	2130	2130	2130	2130	4.7
4.8		Seat height/standing height h <sub>7</sub> (mm)	1005	1005	1005	1005	4.8
4.12		Coupling height h <sub>10</sub> (mm)	375/545	375/545	375/545	375/545	4.12
4.19		Overall length l <sub>1</sub> (mm)	3253	3253	3308	3308	4.19
4.20		Length to face of forks l <sub>2</sub> (mm)	2253	2253	2308	2308	4.20
4.21		Overall width b <sub>1</sub> /b <sub>2</sub> (mm)	1070/–	1070/–	1070/–	1070/–	4.21
4.22		Fork dimensions s/e/l (mm)	40/100/1150	40/100/1150	40/100/1150	40/100/1150	4.22
4.23		Fork carriage ISO 2328, class/type A, B	2A	2A	2A	2A	4.23
4.24		Fork carriage width b <sub>3</sub> (mm)	980	980	980	980	4.24
4.31		Ground clearance, laden, under mast m <sub>1</sub> (mm)	115	115	115	115	4.31
4.32		Ground clearance, centre of wheelbase m <sub>2</sub> (mm)	135	135	135	135	4.32
4.33	Aisle width for pallets 1000 x 1200 crossways Ast (mm)	3578	3578	3623	3623	4.33	
4.34	Aisle width for pallets 800 x 1200 lengthways Ast (mm)	3778	3778	3823	3823	4.34	
4.35	Turning radius Wa (mm)	1975	1975	2020	2020	4.35	
4.36	Smallest pivot point distance b <sub>13</sub> (mm)	560	560	560	560	4.36	
Performance Data	5.1	Travel speed, laden/unladen km/h	18.7/19.0	18.5/19.5	18.4/18.7	18.0/19.0	5.1
	5.2	Lift speed, laden/unladen m/s	0.61/0.65	0.56/0.65	0.60/0.65	0.55/0.65	5.2
	5.3	Lowering speed, laden/unladen m/s	0.56/0.48	0.56/0.48	0.57/0.48	0.57/0.48	5.3
	5.5	Drawbar pull, laden/unladen N	12370/9000	10100/8600	12560/8200	9800/7800	5.5
	5.7	Gradient performance, laden/unladen %	22/25	19/25	20/24	18/24	5.7
	5.9	Acceleration time, laden/unladen s	5.0/4.5	5.0/4.8	5.1/4.4	5.6/5.4	5.9
	5.10	Service brake	mech./hydr.	mech./hydr.	mech./hydr.	mech./hydr.	5.10
V-Motor	7.1	Engine manufacturer/type	Perkins 404C.22	Mazda FE	Perkins 404C.22	Mazda FE	7.1
	7.2	Engine power acc. to ISO 1585 kW	34.1	26	34.1	26	7.2
	7.3	Rated speed 1/min	2400	2400	2400	2400	7.3
	7.4	No. of cylinders/cubic capacity /cm <sup>3</sup>	4/2216	4/1998	4/2216	4/1998	7.4
	7.5	Fuel consumption acc. to VDI cycle l/h, kg/h	2.3 <sup>2)</sup>	1.8 <sup>2)</sup>	2.5 <sup>2)</sup>	2 <sup>2)</sup>	7.5
Other Details	8.1	Type of drive control	hydrodynamic	hydrodynamic	hydrodynamic	hydrodynamic	8.1
	8.2	Operating pressure for attachments bar	160	160	160	160	8.2
	8.3	Oil volume for attachments l/min	45	45	45	45	8.3
	8.4	Sound level at driver's ear according to EN 12 053 dB(A)	76	76	76	76	8.4
	8.5	Tow coupling, type DIN	15170/type H	15170/type H	15170/type H	15170/type H	8.5

1) 427.8 mm for DZ mast; with integrated sideshift: x = 426 mm (450.8 mm for DZ mast); with SS attachment: x = 461.5 mm (486.3 mm for DZ mast)  
 2) 45 VDI working cycles/h

# Make use of the advantages

## Ergonomic operator's cab

The comfortable operator's cab helps maximise the operator's work capacity and offers outstanding ergonomics:

- Large visible step provides easy safe entrance and exit from the cab.
- Cushion cab mountings noticeably reduce vibrations and oscillations.
- Deluxe seat can be adjusted in three ways. Air suspension is available as an option.
- Infinitely adjustable steering column.
- Large, comfortable footwell with automotive style pedal layout.
- Hydraulic levers and directional control are ergonomically positioned to the right of the operator.
- Excellent forward visibility through panoramic mast and carriage.
- Clear visible analogue instrument panel has extensive warning and control lights.
- The optional deluxe cab provides a warm comfortable operating environment in all weathers.

## Engines

Large capacity industrial engines, specially designed for the requirements of forklift trucks provide power in every situation:

- 2.2 litre diesel engine (Perkins), developing 34.1 kW of power with a maximum torque of 143 Nm at 1800 rpm. Clean emissions and quiet combustion by means of indirect injection.
- 2.0 litre gas engine (Mazda), developing 26 kW of power with a maximum torque of 120 Nm at 1600 rpm.
- Long service life due to robust construction and low engine speed.
- 500 hour servicing interval.
- Standard catalytic converter (TFG) for low emissions (NOx, CO, HC), closed-loop 3-way catalyst is optional.
- Low particulate emissions (DFG), with various optional particulate filter systems.
- 42 litre diesel tank integrated in the chassis.

## Hydrodynamic drive

The hydrodynamic drive unit with automatic power shift transmission enables an optimised, suited to requirements power transfer:

- Optimised effectiveness for medium and high speeds.
- Sensitive and shock-free power transfer.
- Combined crawl speed/brake pedal allows sensitive driving while under full lifting performance.

## Electrical system

12 Volt battery with 66 Ah (DFG), 40 Ah (TFG) and 40 A AC alternator. LPG engine with maintenance-free, non-contact electronic ignition.

## Tyres

Super elastic tyres as standard. Non-marking SE tyres or pneumatic tyres available as options.

Front axle				Track	Truck
Tyre type	No.	Size	PR	width	width
SE tyres	2	6.50-10	14	893	1070
Pneumatic tyres	2	6.50-10	14	893	1070
SE wide	2	23x9-10	—	945	1200
SE wide track	2	23x9-10	—	1012	1260
Rear axle				Track	Truck
Tyre type	No.	Size	PR	width	width
SE tyres	2	18x7-8	16	870	
Pneumatic tyres	2	18x7-8	16	870	

## Steering

Hydrostatic steering provides low effort shock free steering, for maximum operator comfort and safety. The steer axle with integrated steering cylinder is fixed to the chassis through rubber bushes.

## Brake

The forklift has two brake systems, a foot operated hydraulic drum service brake with asbestos-free linings and a hand operated "ratchet type" parking brake with warning light.

## Hydraulic system

The high performance filter system ensures clean oil and therefore the long service life of all the components:

- Suction filter and filter in the return line.
- 42 litre hydraulic tank integrated in the chassis.
- The hydraulic tank is vented through a filter.
- Pressure limiting valves prevent excessive pressure and overloads.

## Mast

All components of the mast are designed for excellent visibility, high stability and a long service life:

- Slim line mast sections with lift cylinders hidden behind, give an excellent field of view for safe operation.
- Visibility through the carriage is excellent.
- Carriages comply with FEM/ISO-2328-2A.

## Options

Various special options and mounted equipment are available for adapting to a range of application requirements or customer wishes.

## Jungheinrich UK Ltd.

Head Office:

Sherbourne House  
Sherbourne Drive  
Tilbrook  
Milton Keynes MK7 8HX  
Telephone 01908 363100

info@jungheinrich.co.uk  
www.jungheinrich.co.uk

ISO 9001, ISO 14001  
Certification of Quality and  
Environment Management.



Jungheinrich trucks  
conform to the European  
Safety Requirements.



 **JUNGHEINRICH**  
Well worthwhile