

**Unique truck concept
with front seat and
sideways positioned mast**

**Unobstructed visibility towards
forks, load and travel route**

**Energy reclamation during
lowering and braking**

**3-phase AC technology
with high travel dynamics**

Universal application



EFX 410–413

Electric front seat/tri-lateral stacker (1000–1250 kg)

The tri-lateral stackers EFX 410 and EFX 413 with 48 V 3-phase AC technology, 1000 to 1250 kg capacity and lift heights up to 7000 mm represent versatility and excellent flexibility in the narrow aisle warehouse. The EFX can be utilised in guided or free-range mode. Advantage: combined application in narrow aisle, wide aisle and on the apron.

These versatile application modes are available to the EFX operator with effortless ease: comfortable mounting and dismounting, vibration-absorbing comfort

seat adjustable to height and weight and pedal arrangement as in a motor car. Large depositing areas, clear contours and the latest ergonomic operational devices make work significantly more pleasant and thus faster.

At the centre is the unique truck concept with front seat and sideways positioned mast for unobstructed visibility towards forks, load and travel route. An added plus is the efficiency-promoting operating concept with its operating console that is adjustable in both height and distance to

the operator and its large display. With a number of innovative performance characteristics, it defines state of the art system ergonomics:

- Ergonomic operating elements with thumb control of hydraulic functions for lifting, lowering, turning and reaching.
- Integrated handy steering wheel to support precise and safe handling.
- Information transmission via graphic display. Important operating data are quickly and legibly displayed in pictograms.
- Optimum visibility and thus unobstructed vision towards forks, load and travel route.

EFX 410-413

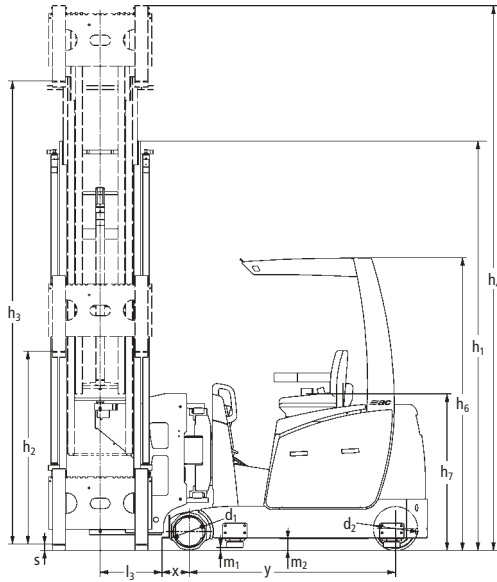

Standard mast designs (mm)

Two-stage mast ZT

h_3	h_4	h_1	h_2
3000	3787	2305*	66
3250	4037	2430	66
3500	4287	2555	66
3750	4537	2680	66
4000	4787	2805	66
4250	5037	2930	66
4500	5287	3055	66
4750	5607	3250	66
5000	5857	3375	66
5250	6107	3500	66
5500	6357	3625	66
5750	6607	3750	66
6000	6857	3875	66

Standard mast designs (mm)

Three-stage mast DZ

h_3	h_4	h_1	h_2
4000	4690	2100*	1410
4250	4940	2190*	1500
4500	5190	2280*	1590
4750	5440	2370	1680
5000	5690	2460	1770
5250	5940	2550	1860
5500	6190	2640	1950
5750	6440	2730	2040
6000	6690	2820	2130
6250	6940	2910	2220
6500	7190	3000	2310
6750	7440	3090	2400
7000	7690	3180	2490

* Attention: overhead load guard height 2277 mm or 2370 mm with flashing beacon on OLG

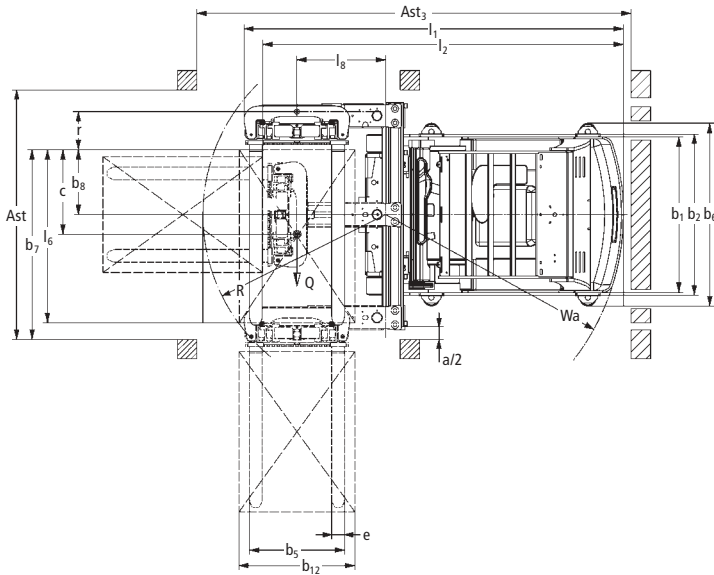

Standard values for working aisle widths (mm)

with rail guidance

Pallet size	Stacking-in depth	A_{st}^*	A_{st3}/VDI theoretical	A_{st3}^{***} practical
1200 x 800	1200	1740	3315	+ 500
1200 x 1200	1200	1740	3730	+ 500
800 x 1200	800	1425**	3652	+ 500

with inductive guidance

Pallet size	Stacking-in depth	A_{st}	A_{st3}/VDI theoretical	A_{st3}^{***} practical
1200 x 800	1200	1810	3315	+ 1000
1200 x 1200	1200	1810	3730	+ 1000
800 x 1200	800	1460	3652	+ 1000

* up to $h_3 = 4000$ mm / +20 mm for $h_3 > 4000$ –6000 mm / +70 mm for $h_3 > 6000$ mm

** Lower values can be achieved if lower rail guide rollers are used.

*** The practical transfer aisle width is a reference value.

Technical Data in line with VDI 2198 as at: 12/2004

Identification	1.1	Manufacturer (abbreviation)	Jungheinrich	Jungheinrich	1.1
	1.2	Manufacturer's type designation	EFX 410	EFX 413	1.2
	1.3	Drive (electric – battery or mains, diesel, petrol, fuel gas, manual)	electric	electric	1.3
	1.4	Type of operation (hand, pedestrian, standing, seated, order picker)	tri-lateral stacker	tri-lateral stacker	1.4
	1.5	Load capacity/rated load Q (t)	1.0	1.25	1.5
	1.6	Load centre distance c (mm)	600	600	1.6
	1.8	Load distance, centre of drive axle to fork x (mm)	210	210	1.8
	1.9	Wheelbase y (mm)	1595	1595	1.9
	Weights	2.1	Service weight incl. battery (see line 6.5) kg	5000	5280
2.2		Axle loading, laden front/rear kg	4826/1254	5331/1279	2.2
2.3		Axle loading, unladen front/rear kg	3185/1815	3300/1980	2.3
Wheels, Chassis	3.1	Tyres (solid rubber, superelastic, pneumatic, polyurethane)	Vulkollan	Vulkollan	3.1
	3.2	Tyre size, front	295 x 144	295 x 144	3.2
	3.3	Tyre size, rear	343 x 140	343 x 140	3.3
	3.5	Wheels, number front/rear (x = driven wheels)	2/1 x	2/1 x	3.5
	3.6	Track width, front b ₁₀ (mm)	1406	1406	3.6
	Basic Dimensions	4.2	Lowered mast height h ₁ (mm)	2805	2805
4.3		Free lift h ₂ (mm)	66	66	4.3
4.4		Lift height h ₃ (mm)	4000	4000	4.4
4.5		Extended mast height h ₄ (mm)	4787	4787	4.5
4.7		Overhead load guard (cab) height h ₅ (mm)	2277	2277	4.7
4.8		Seat height/standing height h ₇ (mm)	1190	1190	4.8
4.19		Overall length (unladen) l ₁ (mm)	3186	3186	4.19
4.20		Length to face of forks l ₂ (mm)	3007	3007	4.20
4.21		Overall width b ₁ /b ₂ (mm)	1210/1550	1210/1550	4.21
4.22		Fork dimensions s/e/l (mm)	100/40/1200	100/40/1200	4.22
4.23		Fork carriage ISO 2328, class/type A, B	2/B	2/B	4.23
4.24		Fork carriage width b ₃ (mm)	890	890	4.24
4.25		Width over forks b ₅ (mm)	850	850	4.25
4.30		Reach, lateral from vehicle centreline b ₆ (mm)	425	425	4.30
4.32		Ground clearance, centre of wheelbase m ₂ (mm)	85	85	4.32
4.33		Aisle width for pallets 1200x800 Ast (mm)	1740	1740	4.33
4.35		Turning radius Wa (mm)	1848	1848	4.35
4.38		Distance to swivelling fork pivot point l ₈ (mm)	893	893	4.38
4.42		Pallet width b ₁₂ (mm)	800	800	4.42
4.43	Pallet length l ₆ (mm)	1200	1200	4.43	
4.49	Distance swivelling forks pivot point – fork carriage r (mm)	265	265	4.49	
Performance Data	5.1	Travel speed, laden/unladen km/h	9/9	9/9	5.1
	5.2	Lift speed, laden/unladen m/s	0.40/0.41	0.40/0.41	5.2
	5.3	Lowering speed, laden/unladen m/s	0.45/0.44	0.45/0.44	5.3
	5.4	Reach speed, laden/unladen m/s	0.20/0.20	0.20/0.20	5.3
	5.10	Service brake	regenerative/hydraulic	regenerative/hydraulic	5.10
	5.11	Parking brake	electric spring-loaded	electric spring-loaded	5.11
E-Motor	6.1	Drive motor rating S ₂ 60 min. kW	4.4	4.4	6.1
	6.2	Lift motor rating at S ₃ 15 % kW	9.5	9.5	6.2
	6.3	Battery acc. to DIN 43531/35/36 A, B, C, no	5 EPzS 575	6 EPzS 690	6.3
	6.4	Battery voltage, nominal capacity K ₅ V/Ah	48/575	48/690	6.4
	6.5	Battery weight kg	856	1011	6.5
Others	8.1	Type of drive control	3-phase AC drive control	3-phase AC drive control	8.1
	8.4	Sound level at driver's ear according to EN 12 053 dB(A)	69	69	8.4
	8.6	Steering	electric	electric	8.6

Make use of the advantages



Operating console

48 V 3-phase AC technology

Constant application of 3-phase AC technology for travel, hydraulics and steering drive is characteristic for the EFX 410–413. The advantages are obvious:

- Optimum energy consumption through particularly favourable efficiency factor.
- High efficiency factor of hydraulic system through rpm control of hydraulic motor.
- Optimised thermal economy allows the use of corrosion-free, heat-resistant plastic containers for hydraulic oil.
- Excellent efficiency factor for motors.
- Dynamic movement sequences.
- Reduced maintenance through omission of components susceptible to wear.

Economic efficiency

During lowering of the load or empty load pick-up device, energy is fed back into the battery = "regenerative lowering". The energy is also fed back into the battery

when braking the travel movement = "regenerative braking". The energy reclaimed in this way is available for subsequent energy consumption. The advantages:

- Longer operating times with the same battery capacity.
- Shorter battery charging times with at the same time longer battery life.
- Lower investment costs for smaller batteries and lower energy costs.

Reliability

3-phase AC drive control and CAN-Bus make EFX applications as requirement-oriented, economical and reliable as never before. The advantages:

- Individual adjustment to every application.
- Active safety through steplessly adjustable speed profiles in narrow aisles and on aprons.
- Care of components.
- Service-friendly through repairable circuit boards and exchangeable interface.

Standard equipment

- Ergonomic operator workplace with overhead load guard.
- Sprung, adjustable and weight-adjustable seat with armrests.
- Operating console adjustable in height and distance to the operator.
- Graphics-suitable display with function keys for status and service displays.
- Ergonomically shaped one-hand operating lever for hydraulic functions.
- Electric power-assisted steering for effortless, sensitive manoeuvring.



Foldable battery cover

- Diagonal travel with optimum speed profile dependent on travel direction.
- Computer-supported truck control with CAN-Bus networking.
- Mirror on overhead load guard.
- 3-fold braking system: regenerative braking, spring-loaded brake on drive wheel and hydraulic load wheel brake.
- Stepless rpm control of all 3-phase AC drives for gentle movement processes at top efficiency factor.
- End position and transfer cushioning with start/stop pads of all hydraulic functions.
- Integrated diagnostic system with display and service interface.
- Removable rear cover for quick access to drive unit.
- Removable battery side panel and foldable battery cover for easy access to built-in battery.

Jungheinrich UK Ltd.

Head Office:

Southmoor Road
Manchester M23 9DU
Telephone 0161 9466600
Telefax 0161 9460195

www.jungheinrich.co.uk

ISO-9001, ISO-14001-
Certification of Quality and
Environment Management.



Jungheinrich trucks
conform to the European
Safety Requirements.



JUNGHEINRICH
Well worthwhile