

Safe handling with tiller in upright position through crawl speed

Impulse control with SpeedControl

Sensitive lowering from the tiller through proportional hydraulics

Extremely flexible through support arm lift

High residual capacities through particularly robust construction



EJC Z14/Z16

Electric pedestrian stacker with support arm lift (1400 kg and 1600 kg)

The Jungheinrich pedestrian stacker EJC Z14/Z16 is a professional with regard to stacking and retrieval. With its powerful 3 kW lift motor, it can stack heavy loads up to 5350 mm lift height (EJC Z14). The Jungheinrich proportional hydraulics ensure gentle lifting and lowering of the load via push button: whether jerk-free depositing, fast lifting and lowering or precise approach of the racking position – the operator always has it all safely “under control”.

The robust and rigid chassis made of 8 mm sheet steel, the stable 4-point bearing surface and the particularly torsion-resistant mast ensure high residual capacities.

The special feature of support arm lift: effortless coping with uneven floors, ramps, transfer plates or loading ramps through additional ground clearance – even fully laden. Though independent homing in on support arm and mast lift, two pallets can be transported at the same time.

Apart from fast lifting, transporting loads is carried out comfortably with the EJC Z14/Z16 with its powerful 1.5 kW motor (EJC Z16). The top speed of 6 km/h is thus reached quickly with or without load.

Thanks to the patented Jungheinrich crawl speed button, the truck is also safely manoeuvrable with the tiller in the upright

position. The low-mounted tiller ensures that the operator is always at a safe distance from the truck.

For particularly long operating times without battery change, the EJC Z14/Z16 can be fitted with battery capacities up to 375 Ah. A 30 A integrated charger (optional) facilitates battery charging at any 230 V mains socket.

EJC Z14/Z16

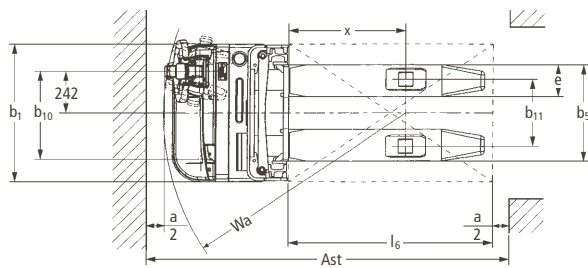
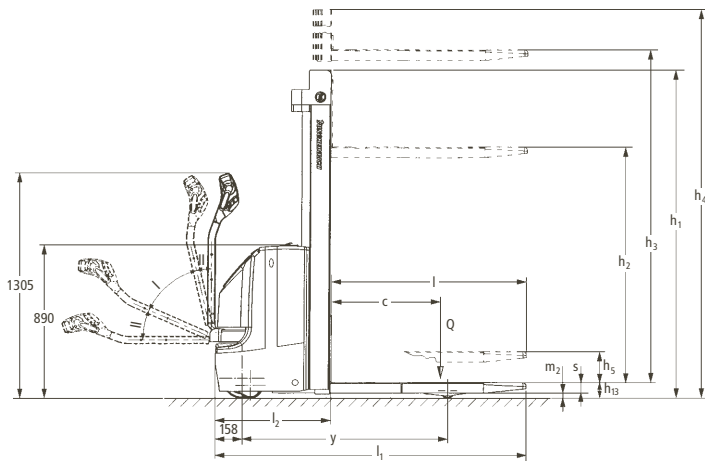

Standard mast types (mm)

| Designation | Closed height | Free lift | Lift height | Extended height | Closed height | Free lift | Lift height | Extended height |
|---------------------|----------------|-----------|-------------|-----------------|----------------|-----------|-------------|-----------------|
| | h_1^* | h_2 | h_3 | h_4 | h_1^* | h_2 | h_3 | h_4 |
| | EJC Z14 | | | | EJC Z16 | | | |
| Two-stage mast ZT | 1750 | 100 | 2500 | 2977 | 1750 | 100 | 2400 | 2927 |
| | 1850 | 100 | 2700 | 3177 | 1850 | 100 | 2600 | 3127 |
| | 1950 | 100 | 2900 | 3377 | 1950 | 100 | 2800 | 3327 |
| | 2110 | 100 | 3200 | 3677 | 2100 | 100 | 3100 | 3627 |
| | 2300 | 100 | 3600 | 4077 | 2300 | 100 | 3500 | 4027 |
| | — | — | — | — | 2450 | 100 | 3800 | 4327 |
| | 2550 | 100 | 4100 | 4577 | 2550 | 100 | 4000 | 4527 |
| 2650 | 100 | 4300 | 4777 | 2650 | 100 | 4200 | 4727 | |
| Two-stage mast ZZ | 1700 | 1223 | 2500 | 2977 | 1700 | 1173 | 2400 | 2927 |
| | 1900 | 1423 | 2900 | 3377 | 1900 | 1373 | 2800 | 3327 |
| | 2050 | 1573 | 3200 | 3677 | 2050 | 1523 | 3100 | 3627 |
| | 2250 | 1773 | 3600 | 4077 | 2250 | 1723 | 3500 | 4027 |
| | 2500 | 2023 | 4100 | 4577 | 2500 | 1973 | 4000 | 4527 |
| 2600 | 2123 | 4300 | 4777 | 2600 | 2073 | 4200 | 4727 | |
| Three-stage mast DZ | 1830 | 1356 | 4090 | 4565 | 1830 | 1306 | 3990 | 4515 |
| | 1900 | 1426 | 4300 | 4775 | 1900 | 1376 | 4200 | 4725 |
| | 2030 | 1556 | 4700 | 5175 | 2030 | 1506 | 4600 | 5125 |
| | 2250 | 1776 | 5350** | 5825 | 2250 | 1726 | 5250** | 5775 |

* with 100 mm free lift
** only EJC Z long

Technical Data in line with VDI 2198 as at: 05/2007

| | | | | | | |
|---|----------------|---|---|-------------------------|-------------------------|------|
| Identification | 1.1 | Manufacturer (abbreviation) | | Jungheinrich | Jungheinrich | 1.1 |
| | 1.2 | Manufacturer's type designation | | EJC Z14 | EJC Z16 | 1.2 |
| | 1.3 | Drive | | electric | electric | 1.3 |
| | 1.4 | Operator type | | pedestrian | pedestrian | 1.4 |
| | 1.5 | Load capacity/rated load | Q (t) | 1.4 | 1.6 | 1.5 |
| | 1.6 | Load centre distance | c (mm) | 600 | 600 | 1.6 |
| | 1.8 | Load distance, centre of drive axle to fork | x (mm) | 897 ^{1) 2)} | 897 ^{1) 2)} | 1.8 |
| | 1.9 | Wheelbase | y (mm) | 1457/1597 ¹⁾ | 1457/1597 ¹⁾ | 1.9 |
| | Weights | 2.1 | Service weight incl. battery (see line 6.5) | kg | 1050 | 1060 |
| 2.2 | | Axle loading, laden front/rear | kg | 1040/1410 | 1090/1570 | 2.2 |
| 2.3 | | Axle loading, unladen front/rear | kg | 760/290 | 770/290 | 2.3 |
| Wheels, Chassis | 3.1 | Tyres | | PU | PU | 3.1 |
| | 3.2 | Tyre size, front | | 230 x 70 | 230 x 70 | 3.2 |
| | 3.3 | Tyre size, rear | | 85 x 95 | 85 x 95 | 3.3 |
| | 3.4 | Additional wheels (dimensions) | | 140 x 54 | 140 x 54 | 3.4 |
| | 3.5 | Wheels, number front rear (x = driven wheels) | | 1x+ 1/2 | 1x+ 1/2 | 3.5 |
| | 3.6 | Track width, front | b ₁₀ (mm) | 505 | 505 | 3.6 |
| | 3.7 | Track width, rear | b ₁₁ (mm) | 375 | 375 | 3.7 |
| Basic Dimensions | 4.2 | Closed mast height | h ₁ (mm) | 1950 | 1950 | 4.2 |
| | 4.3 | Free lift | h ₂ (mm) | 100 | 100 | 4.3 |
| | 4.4 | Lift | h ₃ (mm) | 2900 | 2800 | 4.4 |
| | 4.5 | Height, mast extended | h ₄ (mm) | 3377 | 3327 | 4.5 |
| | 4.6 | Initial lift | h ₅ (mm) | 122 | 122 | 4.6 |
| | 4.9 | Height of tiller in drive position min./max. | h ₁₄ (mm) | 850/1305 | 850/1305 | 4.9 |
| | 4.15 | Height, lowered | h ₁₃ (mm) | 90 | 90 | 4.15 |
| | 4.19 | Overall length | l ₁ (mm) | 1868/2008 ³⁾ | 1868/2008 ³⁾ | 4.19 |
| | 4.20 | Length to face of forks | l ₂ (mm) | 718/858 ³⁾ | 718/858 ³⁾ | 4.20 |
| | 4.21 | Overall width | b ₁ (mm) | 830 | 830 | 4.21 |
| | 4.22 | Fork dimensions | s/e/l (mm) | 56 x 185 x 1150 | 61 x 185 x 1150 | 4.22 |
| | 4.25 | Distance between fork-arms | b ₅ (mm) | 570 | 570 | 4.25 |
| | 4.32 | Ground clearance, centre of wheelbase | m ₂ (mm) | 20 | 20 | 4.32 |
| | 4.33 | Aisle width for pallets 1000 x 1200 crossways | Ast (mm) | 2417/2557 | 2417/2557 | 4.33 |
| | 4.34 | Aisle width for pallets 800 x 1200 lengthways | Ast (mm) | 2310/2450 | 2310/2450 | 4.34 |
| 4.35 | Turning radius | Wa (mm) | 1608/1748 | 1608/1748 | 4.35 | |
| Performance Data | 5.1 | Travel speed, laden/unladen | km/h | 6.0/6.0 | 6.0/6.0 | 5.1 |
| | 5.2 | Lift speed, laden/unladen | m/s | 0.15/0.23 | 0.14/0.23 | 5.2 |
| | 5.3 | Lowering speed, laden/unladen | m/s | 0.40/0.40 | 0.40/0.40 | 5.3 |
| | 5.8 | Max. gradeability, laden/unladen | % | 8/16 | 7/16 | 5.8 |
| | 5.10 | Service brake | | electric | electric | 5.10 |
| Electric engine | 6.1 | Drive motor rating S ₂ 60 min. | kW | 1.3 | 1.5 | 6.1 |
| | 6.2 | Lift motor rating at S ₃ 15 % | kW | 3 | 3 | 6.2 |
| | 6.3 | Battery acc. to DIN 43531/35/36 A, B, C, no | | (no) 2 EPzB | (no) 2 EPzB | 6.3 |
| | 6.4 | Battery voltage, nominal capacity K ₅ | V/Ah | 24/200 24/375 | 24/200 24/375 | 6.4 |
| | 6.5 | Battery weight | kg | 185 | 185 | 6.5 |
| Others | 8.1 | Type of drive control | | SpeedControl | SpeedControl | 8.1 |
| | 8.4 | Sound level at the driver's ear according to DIN 12 053 | dB(A) | 65 | 65 | 8.4 |
| 1) Load section raised –60 mm 2) DZ –38 mm (EJC Z16: DZ –43 mm) 3) DZ +38 mm (EJC Z16: DZ +43 mm) | | | | | | |

This specification sheet according to VDI regulation 2198 only provides technical values for the standard truck. Non-standard tyres, different masts, additional equipment, etc. could produce other values. Right reserved for technical changes and improvements.

Make use of the advantages



Travel over loading ramp with EJC Z

High performance efficiency in every situation

The EJC Z14/Z16 is designed for the most intensive applications. Its powerful 3 kW lift motor and 1.5 kW drive motor ensure highest throughput efficiency. Other advantages:

- 8 mm strong steel chassis.
- Specially torsion-resistant mast with high residual capacities.
- Lift heights up to 5350 mm (EJC Z14).

"Intelligent" controls and progressive drive technology

Shunt wound drive technology and SpeedControl ensure safe travel characteristics with adjustment opportunities for every application:

- The travel speed set on the travel switch is adhered to in every travel situation – also on upward and downward gradients.
- The EJC Z is automatically braked during unintentional rolling on ramps.
- Individually adjustable travel parameters facilitate optimum adjustment to every application.

- Energy reclamation through regenerative braking on reduction of travel speed.
- 2-year warranty on drive motor.

Comfortable stacking and retrieval

Remarkable safety for the operator with proportional hydraulics. All lifting and lowering functions can be sensitively controlled with the multi-function tiller head without reaching round.

- Panorama mast with extra wide window and slim mast profiles for excellent visibility.
- Automatic travel speed reduction during lifting above approx. 1800 mm lift height when fitted with large masts.
- Long tiller ensures safe distance between operator and truck as well as lower steering forces.
- Rounded and enclosed truck contours.
- 4-wheel concept for excellent stability.
- The support arms are lowered automatically from approximately 1800 mm stacking-in height.

Effortless manoeuvring

Space-saving through crawl speed button: to reduce the turning radius, the separate



Stacking with EJC Z14



Doubledeck transport of two pallets

tiller switch also facilitates manoeuvring with the tiller in upright position.

Versatile through support arm lift

Support arm lift independent of the forks through a second lift mechanism – the support arm lift. Thus the EJC Z14/Z16 is able to cope effortlessly with uneven floors, ramps or loading ramps. Support arm and mast lift work independently from each other. The advantage: double-deck transport of two pallets at the same time.

Long operating times

Battery capacities up to 375 Ah ensure long operating times.

- Short version: 2 PzB 200 Ah.
- Long version: 3 EPzS 270/375 Ah.
- Effortless charging at any mains socket through integrated 24 V/30 Ah charger (optional).

Additional equipment

- Cold store version.
- Vertical load guard.
- Truck activation via PIN entry.

Jungheinrich UK Ltd.

Head Office:

Sherbourne House · Sherbourne Drive
Tilbrook · Milton Keynes MK7 8HX
Phone 01908 363100
Fax 01908 363180

info@jungheinrich.co.uk
www.jungheinrich.co.uk

Jungheinrich AG
ISO 9001, ISO 14001
Certification of Quality and
Environment Management.



Jungheinrich trucks
conform to the European
Safety Requirements.



JUNGHEINRICH
Well worthwhile